



Republic of the Philippines
Department of Environment and Natural Resources
BIODIVERSITY MANAGEMENT BUREAU
Ninoy Aquino Parks and Wildlife Center, Quezon Avenue, Diliman, 1100 Quezon City
Tel. Nos.: (632) 8924-6031 to 35 | Fax: (632) 8924-0109, (632) 8920-4417
Website: <https://bmb.gov.ph> | E-mail Address: bmb@bmb.gov.ph

INVITATION TO BID No. 2023-024

The Biodiversity Management Bureau (BMB), through the Bids and Awards Committee (BAC) invites contractors to bid for the hereunder project:

Name of Project : **SUPPLY & INSTALLATION OF WAITING SHED FOR USE OF THE EXISTING CITIZEN CHARTER INFO BOARD**
Brief Description : Furnishing of labor, materials and equipment necessary to complete the project located inside the Ninoy Aquino Parks and Wildlife Center, Quezon Avenue, Diliman, Quezon City
Approved Budget
For the Contract : P365,681.12
Source of Funding : Fund 101. Continuing Fund (CA-1a/CA 2b)
Contract Duration : 24 Working Days

Prospective bidders should have completed a similar contract with a value of at least 50% of the ABC, and have key personnel and equipment available for the execution of the contract. Conduct of a site inspection and submission of site investigation report is a requirement before the submission of bid proposals. The deadline for submission of bid proposals will be on **JUL 12 2023** at the BMB-BAC Secretariat, Administration Building, Ninoy Aquino Parks and Wildlife Center, North Avenue, Diliman, Quezon City. The BAC will conduct post-qualification of the lowest calculated bid.

The Biodiversity Management Bureau will assume no responsibility whatsoever to compensate or indemnify bidders for any expenses incurred in the preparation of the bid.

Approved for Posting:

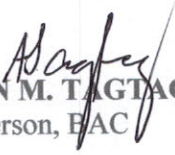
ANSON M. TAGTAG
Chairperson, BAC



UNITED NATIONS DECADE ON
**ECOSYSTEM
RESTORATION**
2021-2030

BILL OF QUANTITIES
FINANCIAL BID FORM/SUMMARY OF COST ESTIMATE

**Project Name: SUPPLY & INSTALLATION OF WAITING SHED FOR USE
OF THE EXISTING CITIZEN CHARTER INFO BOARD**

Location: BMB, Quezon Ave., Diliman Quezon City

ITEM	DESCRIPTION	UNIT	QUANTITY	UNIT COST	AMOUNT
I.	SITE PREPARATION/MOBILIZATION & DEMOBILIZATION	lot	1.00		
II.	EXCAVATION WORKS	cu.m.	0.90		
III.	FOOTING & PEDESTAL COLUMN STEEL WORKS	kg	47.22		
IV.	FOOTING CONCRETING	cu.m.	0.30		
V.	PEDESTAL COLUMN FORMWORKS	sq.m.	2.80		
VI.	PEDESTAL COLUMN CONCRETING	cu.m.	0.20		
VII.	STRUCTURAL STEEL WORKS (STEEL POSTS AND TRUSSES)	kg	243.58		
VIII.	PAINTING WORKS	sq.m.	18.69		
IX.	ROOF INSTALLATION	sq.m.	20.16		
X.	CLEANING/CLEARING & TURN-OVER	lot	1.00		

TOTAL COST (DIRECT COST+INDIRECT COST)= _____

AMOUNT IN WORDS: _____

CONTRACTOR'S NAME WITH SIGNATURE ABOVE: _____

COMPANY NAME: _____

DATE: _____

**SUPPLY & INSTALLATION OF WAITING SHED FOR USE OF THE EXISTING
CITIZEN CHARTER INFO BOARD**

ABC: P365,681.12

DOCUMENTS FOR SUBMISSION:

1. Registration certificate from the Securities and Exchange Commission (SEC), Department of Trade and Industry (DTI) for sole proprietorship, or Cooperative Development Authority (CDA) for cooperatives whichever is applicable;
2. Mayor's permit issued by the city or municipality where the principal place of business of the prospective bidder is located;
3. Statement of all its ongoing and completed government and private contracts which are similar in nature within five (5) years from the submission of bids, including contracts awarded but not yet started, if any;
4. Valid Philippine Contractors Accreditation Board (PCAB) license and registration for the type and cost of the contract for this Project; and
5. Certificate of PhilGEPS Registration
6. Latest Income Tax Return (ITR)
7. Detailed Cost Estimates
8. Bill of Quantities
9. Notarized Omnibus Sworn Statement (OSS)
10. Certificate of Site Inspection

11. List of manpower, materials, and equipment necessary for the project in accordance with the approved Plans, Scope of Works and Technical Specifications;
12. The Contractor shall submit pictures taken before, on-going, and after the construction;
13. The Contractor shall submit on the last working day a Statement of Work Accomplished (SOWA) addressed to the Director of Administrative Service or any duly authorized representative.

Project Title: PROPOSED CONSTRUCTION OF WAITING SHED FOR USE OF THE EXISTING BIODIVERSITY MANAGEMENT BUREAU CITIZEN CHARTER INFO BOARD OF THE BMB

Location : DENR - BIODIVERSITY MANAGEMENT BUREAU, North Ave., Diliman, Quezon City

Subject : Scope of Works and Technical Specifications

Item I. SITE PREPARATION/MOBILIZATION & DEMOBILIZATION

The works under this item shall include the transportation of needed materials, labor and equipment from legal sources to the project site for the *Proposed Improvement of ARTA Info Board with Included Construction of Waiting Shed* located at BMB Quezon Ave., Diliman, Quezon City. Aforesaid activities shall be done carefully and properly as directed. For other details, please refer to the approved plans/drawings.

Item II. CLEARING WORKS

The works under this item shall include the proper clearing needed at the located project site. This includes the clearing of existing shrubs and other debris that are obstructing the upcoming excavation works. Likewise, the project site shall be cleared of all debris/wastes, obstructions and other objectionable matters as directed.

Item III. EXCAVATION WORKS

The works under this item shall include the laying-out of the foundations instructed in the approved plans/drawings and implementing the required excavation. The excavation includes the foundation of concrete pedestals with a strictly required depth of greater than or equal to 0.6m from the natural grade line. Proper use of equipment such as shovel and digging bar will be observed. Pouring of gravel(G1) beddings to the foundation before concreting is also strictly required. For other details, please refer to the approved plans/drawings.

Item IV. STEEL WORKS(REBARS)

The works under this item shall include the fabrication of the concrete pedestal footing rebars and concrete pedestal rebars. Required rebars and tie wires in the fabrication shall be 12mmØ and 10mmØ bars and #16 GI tie wire. The fabrication includes the footing rebar composing of 12mmØ bars and pedestal rebar composing of 10mmØ bars both main bars and lateral ties. Also included under this item is the proper installation of the fabricated rebars, this includes the concrete spacers for foundations with a height of 75mm. For other details, please refer to the approved plans/drawings.

Item V. FORMWORKS

The works under this item shall include the proper installation of formworks for the concreting of concrete pedestals. The use of phenolic board ½" and coco lumber is required. Concrete spacers for the concrete pedestal with a height of 50mm is also required. For other details, please refer to the approved plans/drawings.

Item VI. CONCRETING

The works under this item shall include the required Class A mix of concrete and the proper concreting of the footing and the pedestal. The required mix must have a strength of 3,000 to 5,000 psi. Proper concreting of the foundation and pedestal includes the pouring and spreading of the concrete evenly throughout the form. This is required to avoid the forming of bubbles that can create voids that lowers the compaction strength of the concrete. Before the concreting of the pedestal, 4 - 12mmØ anchor bolts with 300mm length should be placed and attached to the installed main rebar of the pedestal with locations as shown in the approved plans/drawings. For other details, please refer to the approved plans/drawings.

Item VII. STRUCTURAL STEEL WORKS

The works under this item shall include the installation of tubular steel columns and fabrication and installation of tubular steel rafters and battens. This includes welding works and cutting lists of tubular steel. Refer to the approved plans/drawings for the tubular steel sizes used in the fabrication and installation. Base plates of 0.15m x 0.15m x 8mm with 4 - 12mmØ holes as shown in the plans/drawings are to be fully welded at the base of the tubular steel column to be installed at the concrete pedestal. Full weld installation will be used for the installation of tubular steel rafters and battens. For other details, please refer to the approved plans/drawings.

Item VIII. PAINTING WORKS

The works under this item shall include the painting finish of the steel base plate and tubular steel columns, rafters and battens. Application of epoxy primer for steel painting are required before applying 2 coats of enamel or oil-based paints to add treatment and prolong the lifespan of the steel structure. For other details, please refer to the approved plans/drawings.

Item IX. ROOF INSTALLATION AND CLEARING

The works under this item shall include the installation of polycarbonate solid sheet as roofing and clearing works after the completion of the project. The polycarbonate solid sheet to be used will have a thickness of 6mm and will be installed using 1 inch self-tapping screws spaced as shown in the approved plans/drawings. Silicon sealant will be used as sticking agent for connecting the polycarbonate solid sheets and as additional accessory, aluminum U-clip ¼" x 12' will be installed at the edges of the installed polycarbonate solid sheet for safety and aesthetic purposes. For completion and turn-over requirements, cleaning and clearing of the project site will be required. For other details, please refer to the approved plans/drawings.

Reviewed and Concurred by:

Noted by:



ENGR. MELCHOR Q. BANGAOIL
Engineer II, BMB PROJECT ENGINEER

RODNEY EMMANUEL M. ANSELMO
Head, General Services Unit

Recommended by:

ANSON M. TAGTAG
OIC, CAWED and
Chairperson, BMB – Committee
on Anti – Red Tape

Approved by:

MARCIAL C. AMARO JR.
Director, BMB in concurrent capacity as
Assistant Secretary for Policy, Planning and
Foreign-Assisted and Special Projects



DEPARTMENT OF ENVIRONMENT
AND NATURAL RESOURCES
BIODIVERSITY MANAGEMENT BUREAU

PROJECT TITLE:
PROPOSED CONSTRUCTION OF WAITING SHED FOR
USE OF THE EXISTING CITIZEN CHARTER (INDO BOARD)
PROJECT LOCATION:
NINYO AQUINO PARKS AND WILDLIFE CENTER,
QUEZON AVENUE, DILIMAN, QUEZON CITY

SHEET CONTENTS:

PERSPECTIVE PLAN

REVIEWED BY:

Melchor O. Serrano
MELCHOR O. SERRANO
ENGINEER II
BMB PROJECT ENGINEER

RECOMMENDING APPROVAL:

ANSON M. TAYG
ANSON M. TAYG
OIC CAWED
CHAIRPERSON, BMB-COMMITTEE ON ANTI-RED TAPE

APPROVED BY:

MARCIAL C. AMARRO, JR.
MARCIAL C. AMARRO, JR.
DIRECTOR, BMB
IN CHARGE, CURRENT CAPACITY AS ASSISTANT SECRETARY
FOR POLICY, PLANNING AND FORECASTING-ASSISTED AND
SPECIAL PROJECTS

SHEET NO.

2
of
2
sheets

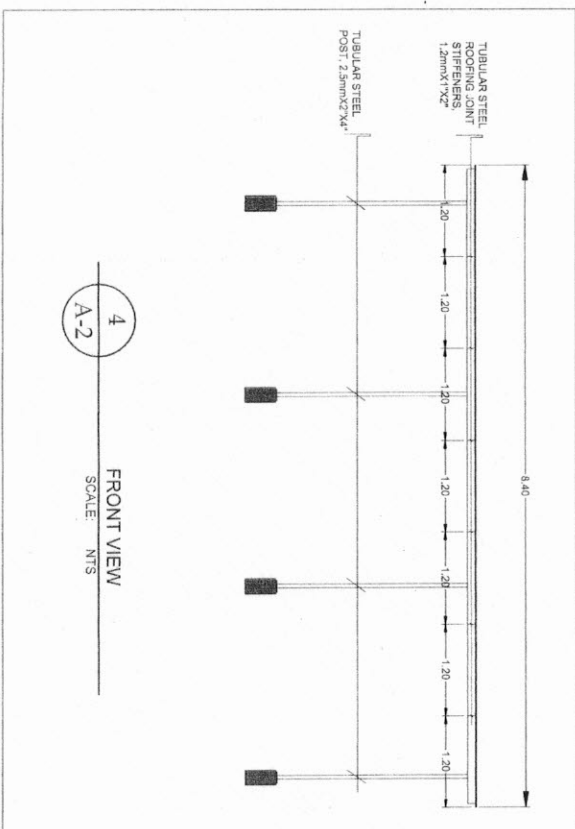
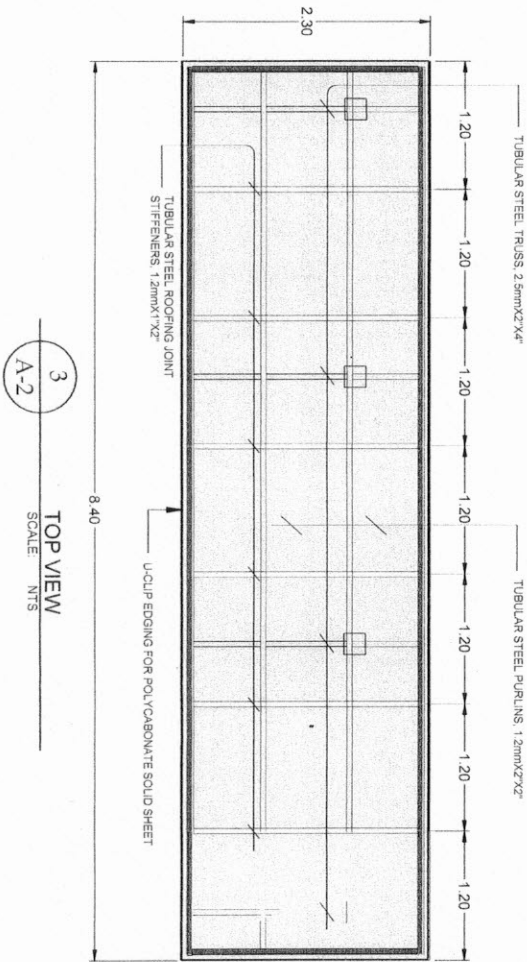
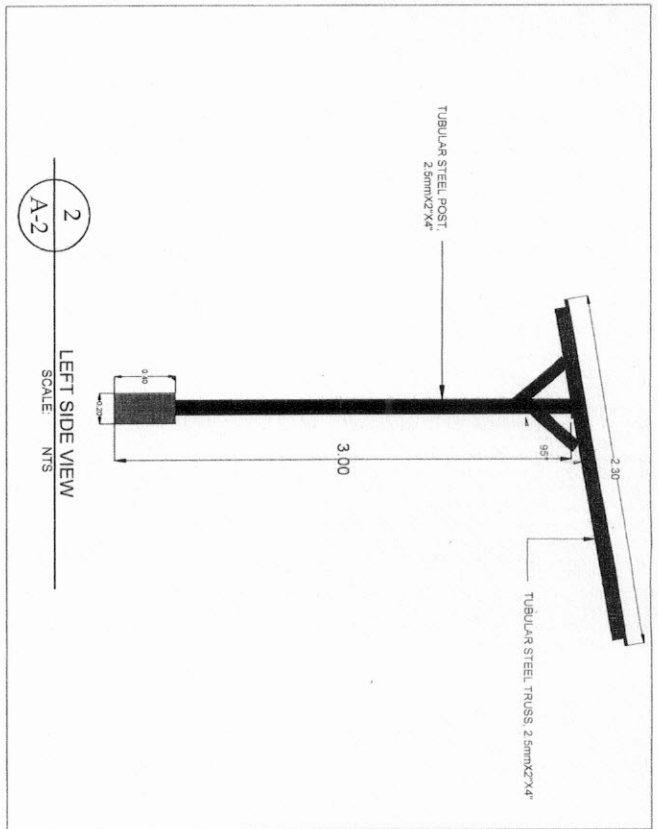
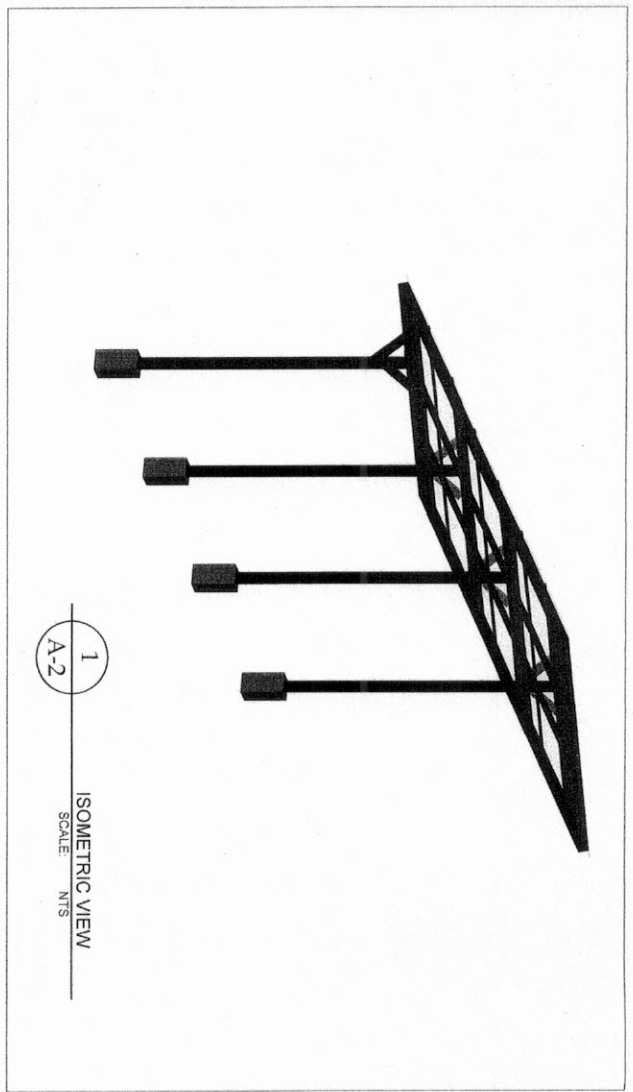



DEPARTMENT OF ENVIRONMENT
AND NATURAL RESOURCES
BIODIVERSITY MANAGEMENT BUREAU

PROJECT TITLE:
PROPOSED CONSTRUCTION OF WAITING SHED FOR
USE OF THE EXISTING CITIZEN QUARTER IN PD BOARD
PROJECT LOCATION:
NINYO AQUINO PARKS AND WILDLIFE CENTER,
QUEZON AVENUE, DILIMAN, QUEZON CITY

SHEET CONTENTS:
FOUNDATION PLAN
PEDESTAL COLUMN/FOOTING

REVIEWED BY:
Melchor O. Zamora
MELCHOR O. ZAMORA
ENGINEER
BMB PROJECT ENGINEER

RECOMMENDING APPROVAL:
CHC CAVED
ANSON M. TAGAG
CHAIRPERSON, BMB-COMMITTEE ON ANTIFERD TAPE

APPROVED BY:
Marcial C. Avador Jr.
MARCIAL C. AVADOR JR.
DIRECTOR, BMB
IN CONCURRENT CAPACITY AS ASSISTANT SECRETARY
FOR POLICY PLANNING AND FOREIGN-ASSISTED AND
LOCAL PROJECTS

SHEET NO.
1
of
1
sheet

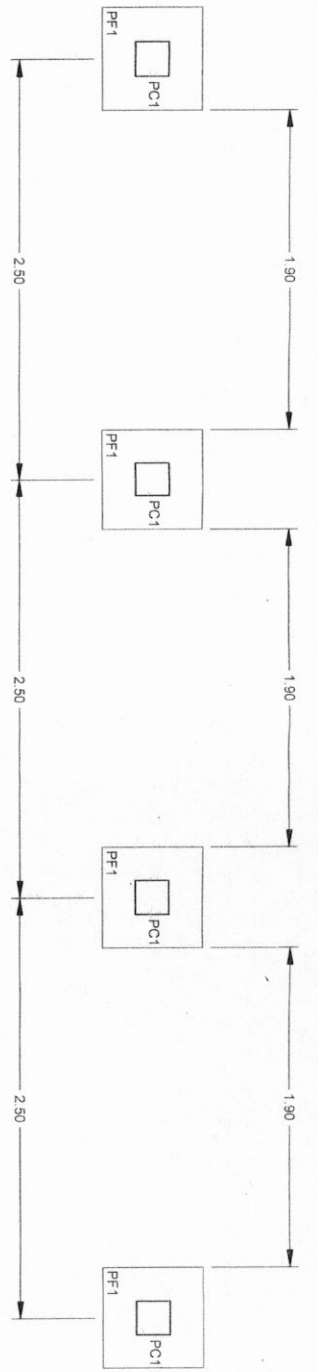

1
FOUNDATION PLAN
SCALE: NTS

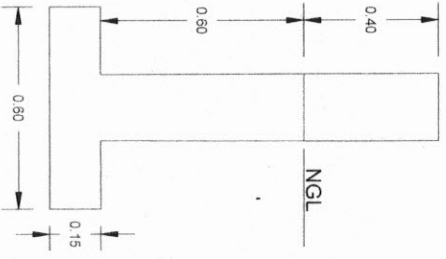

2
PEDESTAL COLUMN/FOOTING
SCALE: NTS

